

CIRCUIT BREAKERS for DISTRIBUTION TRANSFORMERS

CATALOG NUMBER AND FEATURE TABLE

STANDARD BREAKERS - WITH LIGHT SWITCH AND EMERGENCY OVERLOAD

TRANSFORMER kVA		CATALOG NUMBER	DRAWING NUMBER	AMPERE RATING
120 / 240 VOLT SECONDARY	240 / 480 VOLT SECONDARY			
TYPE T - 13				
75		7561ZD8799	2501KO64G01	313
100		7561ZD8899	2501KO64G02	417
	167	7561ZD8999	2501KO64G03	348
TYPE T - 14				
167		7561ZD9099	2501KO65G01	694
	333	7561ZD9099	2501KO65G01	694

- Last six digits of the drawing number are marked on the breaker frame.
- All T - 13 and T - 14 Type Breakers have the signal light switch and emergency overload. If the emergency overload feature is not to be used, restrain the emergency overload lever in the normal position.

UNLESS OTHERWISE SPECIFIED, TOLERANCES ARE

SURFACES	2 PL DEC	3 PL DEC	ANGLES
✓	±	±	± DEG

FIRST MADE FOR DT8D T13M

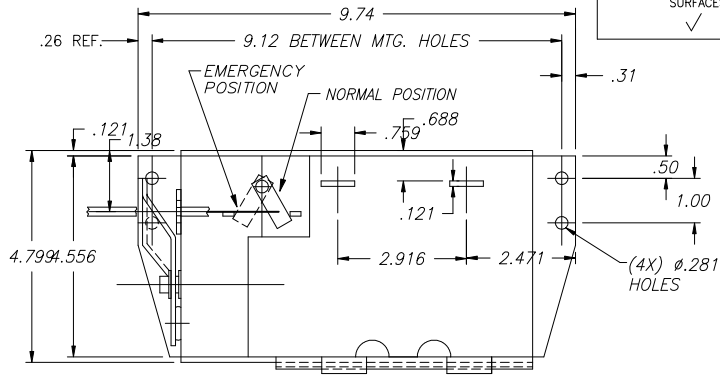

BREAKER WITH MAGNETIC TRIPOUT

CALIBRATION	KVA	G.E. CAT. NO.	DRAWING NO.	L.V. RATING
A2541K049	75	7561ZD8799	2501K064G01	120/240
A2541K048	100	7561ZD8899	2501K064G02	120/240
A2541K051	167	7561ZD8999	2501K064G03	240/480

KVA	TRIP TEMP DEG. C				BREAKER BIMETAL RESISTANCE OHMS/CMF=G
	NORM SIG. LT.	EMERG. SIG. LT.	NORM BRK	EMERG. BRK	
75	120	120	165	180	30
100	132	132	172	192	30
167	125	125	165	185	30

ULTIMATE RISE = $216 \left(\frac{G}{20}\right) .75 \left(\frac{1}{2860}\right) 1.5$
 FOR CURVE OF TEMP. VS CURRENT SEE DWG. 187HA840
 FOR CURVE OF TIME VS CURRENT SEE DWG. 187HB839

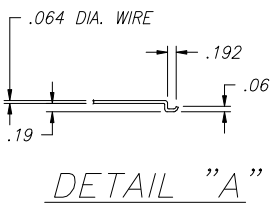

IF ALTERNATE HLS ARE USED ROTATE THIS LINE 15° PER HOLE
 SQUEEZE TO CLAMP SPRING
 CENTER HOLE ALTERNATES MAY BE USED IF NEEDED.

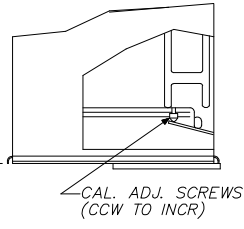
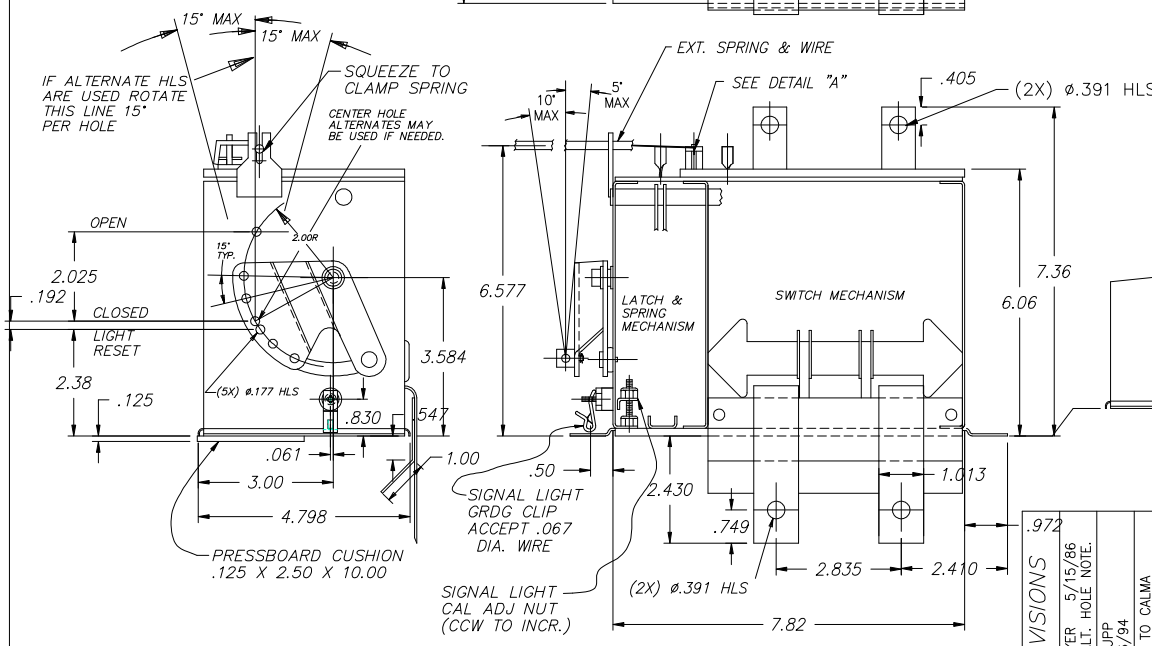

RECALIB. TO NEW TRIP TEMP.

$$I_{NEW} = I_{OLD} \sqrt{\frac{T_2 - T_0}{T_1 - T_0}}$$

I_{NEW} = NEW CALIB CURRENT
 I_{OLD} = OLD CALIB CURRENT
 T_2 = NEW TRIP TEMP.
 T_1 = OLD TRIP TEMP.
 T_0 = OIL TEMP.

REVISIONS	DATE	BY	DESCRIPTION	APPROVALS	PRINTS TO
1	5/15/86	L. SAWYER	ADD ALT. HOLE NOTE.		
2	03/16/94	D. KANUPP	RETRAGED TO CALMA		
3	16 MAR 95	RTCD	ACAD CHG RTG		
4	02/05/96	G. BRYANT	ECON#86; Updated breaker table to = products & BOM		
5	07/09/1996	G. BRYANT	Corrected dim. & calibration typos (A2541K051, net50)		
6	28-JAN-99	STULPIN	UPDATED TEMPLATE		
7	31-MAY-00	STULPIN	CHG SCREW SIZE - WAS #6-40		
8	18-APRIL-02	GILLAND	ECON: NONE		
			ADD GRD CLIP		
			ECON: FB10		

MADE BY: J. HAYMAN 7-20-77
 REISSUED BY: R. GILLAND 18-APRIL-02

HICKORY ERMCO

B 2551K096
 CONT ON SH SH

A2-3

04/02

UNLESS OTHERWISE SPECIFIED, TOLERANCES ARE			
SURFACES	2 PL DEC	3 PL DEC	ANGLES
✓	±	±	± DEG

FIRST MADE FOR T14 M

BREAKER WITH MAGNETIC TRIPOUT				
CALIBRATION	KVA	G.E. CAT. NO.	DRAWING NO.	L.V. RATING
A2541K050	167	7561ZD9099	2501K065G01	120/240

KVA	TRIP TEMP DEG. C				BREAKER BIMETAL RESISTANCE OHMS/CMF=G
	NORM SIG. LT.	EMERG. SIG. LT.	NORM BRK	EMERG. BRK	
167	128	128	170	190	30

ULTIMATE RISE = $246 \left(\frac{G}{30}\right) \cdot 75 \left(\frac{I}{4350}\right) 1.5$

FOR CURVE OF TEMP. VS CURRENT SEE DWG. 187HA840
FOR CURVE OF TIME VS CURRENT SEE DWG. 187HB839

NOTE 1. CONNECTIONS TO THESE TERMINALS MUST USE ONE CONNECTOR ON EACH SIDE OF EACH TERMINAL.

RECALIB. TO NEW TRIP TEMP.

$$I_{NEW} = I_{OLD} \sqrt{\frac{T_2 - T_0}{T_1 - T_0}}$$

I_{NEW} = NEW CALIB CURRENT
 I_{OLD} = OLD CALIB CURRENT
 T_2 = NEW TRIP TEMP.
 T_1 = OLD TRIP TEMP.
 T_0 = OIL TEMP.

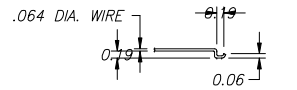

DETAIL "A"

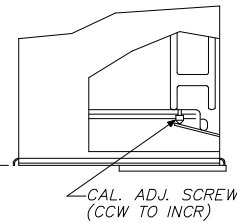
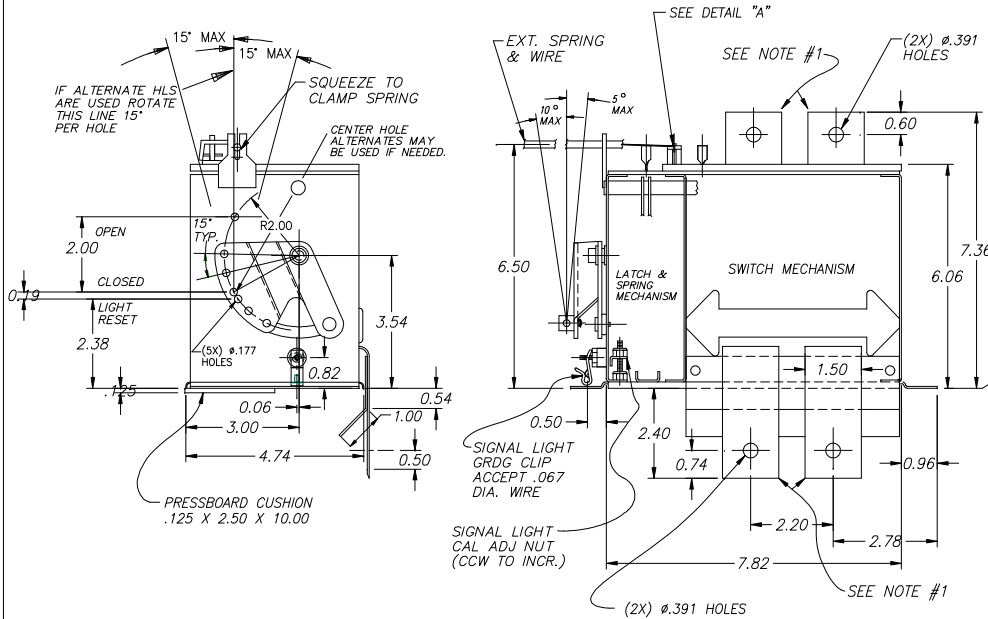
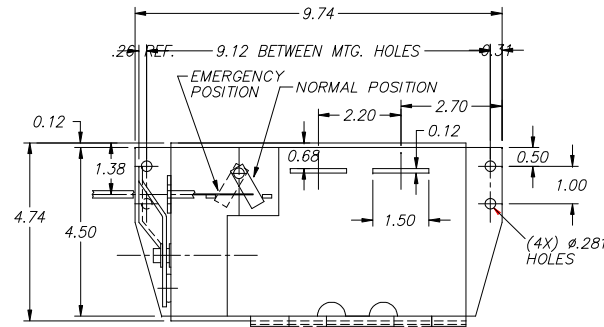

REVISIONS		APPROVALS		HICKORY ERMCO		B 2551K097	
1	L. SAYER 5-15-86 ADD ALT HOLE NOTE						
2	D. KANIPP 16 JAN 94 Retraced to CALMA (Letter converted to ACAD by ABD)						
3	G. BRYANT 07/09/1996 Found orig. dwg. corrected dims & typos						
4	STULPIN 28-JAN-99 UPDATED TEMPLATE						
5	STULPIN 31-MAY-00 CHG SCREW SIZE-WAS #6-40 ECN: NONE						
6	GILLAND 18-APRIL-02 ADD GRD CLIP ECN: FB10						
MADE BY: J. HAYMAN 7-21-77		REISSUED BY: R. GILLAND 18-APRIL-02		APPROVALS		HICKORY ERMCO	
						B 2551K097	
						CONT ON SH SH	

A2-4

04/02