



UNLESS OTHERWISE SPECIFIED, TOLERANCES ARE:
 SURFACES 2 PL DEC ±
 ANGLES 3 PL DEC ±
 DEGS ±

TITLE
 OUTLINE: BREAKER ASM
 FIRST MADE FOR T1 & T12 Bkrs (BOB)

32B128001
 CONT ON SH 2
 SH 1

EMERGENCY OVERLOAD HANDLE, IF REQUIRED

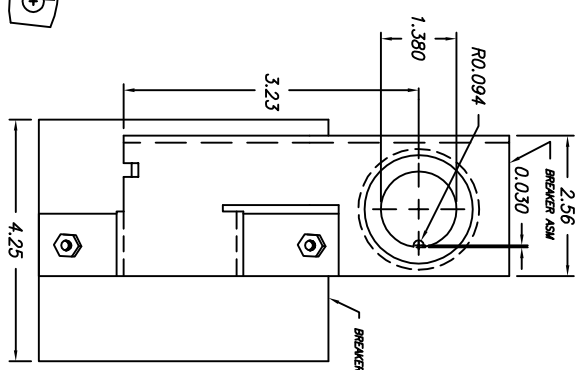
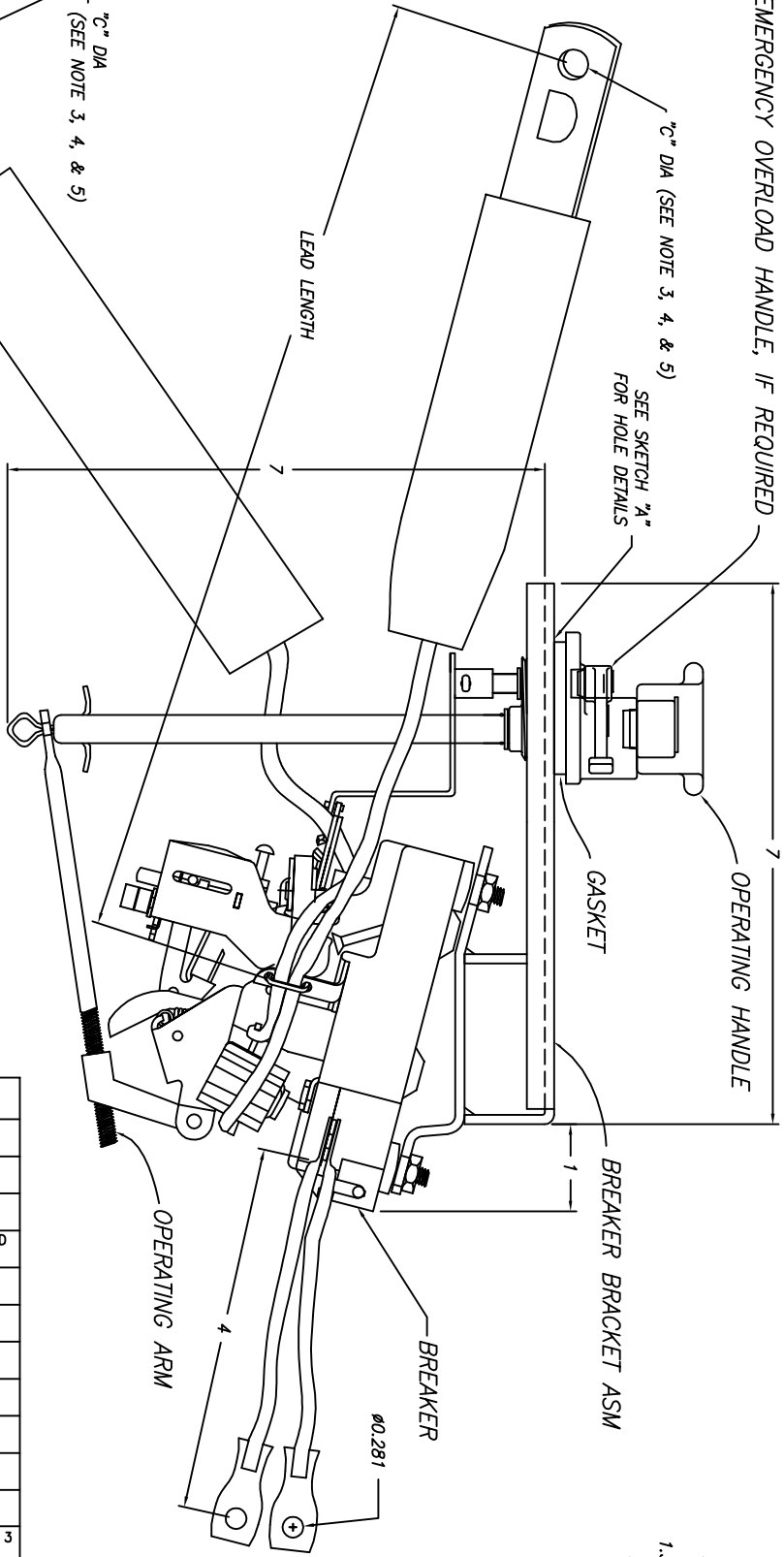

- NOTES:
1. FOR MOUNTING HOLE DIMENSIONS, SEE PAGE A4-3, SKETCH "A".
 2. FOR CATALOG NUMBERS, SEE TABLE ON SHEET 2.
 3. "C" = 0.406 FOR 5, 10, AND 15 KVA MODELS.
 "C" = 0.531 FOR 25, 37.5, AND 50 KVA MODELS.
 "C" = 0.625 FOR 7561ZH3899 - "C" = 0.406
 4. FOR 7561ZH3899 - "C" = 0.406
 5. FOR 7561ZH3899 - "C" = 0.625
 6. FOR 7561ZH4099 "C" = 0.406

REVISIONS	
1	STULPIN 04-FEB-99 UPDATED TEMPLATE
2	STULPIN 07-MAR-01 ADD DIMS & NOTES; ADDED SHEET 2; ECN: NONE
3	GILLAND 07-AUG-01 ADD NOTE 4 ECNF727
4	GILLAND 29-MAY-03 ADD NOTE 5 ECN F903
5	N. Adams 2/11/05 Added BOB to (first made for)
17	N. Adams 4/13/06 Add 7561ZH4099 on sh. 3 ECN F992
18	N. Adams 8/08/06 Correct ZX3299 Add ZH3999 ECN F1004
19	N. Adams 9/07/06 Correct ID # 7561ZH2599, 2999 & 3099 ECN F1010

MADE BY: S. STULPIN 16-June-97
 ISSUED BY: Nicholas Adams 9/07/06
 ECN #F198
 APPROVALS
 ECI
 CONT ON SH 2
 32B128001
 SH 1

OUTLINE: BREAKER ON A BRACKET ASSEMBLY

FIRST MADE FOR

T1 & T12 BREAKERS (PROLEC)

Cat Number	Description	Voltage	ID	Trip Temp	Lead Length		# of Leads	Curve
					"A"	"D"		
								GES6301A
7561ZH2099	10 KVA EC&S	120/240	2501K182G16	110	13	13	2	10
7561ZH2399	7.5 KVA EC&S	120/240	2501K182G59	110	13	13	4	7.5
7561ZH2499	37.5 KVA EC&S	120/240	2501K185G04	160	13	13	4	37.5
7561ZH2599	50 KVA EC&S	120/240	2501K185G05	160	8	13	2	50
7561ZH2699	10 KVA EC&S	120/240	2501K182G03	150	8	15	2	10
7561ZH2799	15 KVA EC&S	120/240	2501K182G04	153	8	15	2	15
7561ZH2899	5 KVA EC&S	120/240	2501k182G64	120	13	13	2	5
7561ZH2999	7.5 KVA EC&S	120/240	2501K182G02	145	8	13	2	7.5
7561ZH3099	50 KVA	120/240	2501K213G45	130	8	17	4	50
7561ZH3199	7.5 KVA	120/240	2501K212G09	110	13	13	4	7.5
7561ZH3299	10 KVA	120/240	2501K212G08	110	13	13	2	10
7561ZH3399	37.5 KVA	120/240	2501K213G09	110	13	13	4	37.5
7561ZH3499	10 KVA	120/240	2501K212G10	110	13	13	2	10
7561ZH3599	50 KVA	120/240	2501K213G09	110	8	17	4	50
7561ZH3699	25 KVA	120/240	2501K212G11	120	13	13	4	25
7561ZH3799								
7561ZH3899	50 KVA	120/240	2501K185G51	160	9	15	4	50
7561ZH3999	15 KVA EC&S	120/240	2501K182G69	110	13	13	2	15
7561ZX0299	25KVA EC&S	120/240	2501K182G57	110	13	13	4	25
7561ZX1099	37.5 KVA EC&S	120/240	2501K185G18	110	13	13	4	37.5
7561ZX1199	50 KVA EC&S	120/240	2501K185G19	115	8	8	4	50
7561ZX1299	5 KVA EC&S	120/240	2501K182G44	110	13	13	2	5
7561ZX1399	10 KVA EC&S	120/240	2501K182G08	130	13	13	2	10
7561ZX1499	25 KVA EC&S	120/240	2501K182G54	130	13	13	4	25
7561ZX1799	15 KVA EC&S	120/240	2501K182G23	130	13	13	2	15
7561ZX1899	50 KVA EC&S	120/240	2501K185G19	110	8	8	4	50
7561ZX1999	25 KVA EC&S	120/240	2501K182G55	120	13	13	4	25
7561ZX2099	15 KVA EC&S	120/240	2501K182G04	153	13	13	2	15
7561ZX2199	15 KVA EC&S	120/240	2501K182G38	120	13	13	2	15
7561ZX2399	5 KVA EC&S	120/240	2501K182G15	145	13	13	2	5
7561ZX2499	10 KVA EC&S	120/240	2501K182G03	150	13	13	2	10
7561ZX2599	15 KVA EC&S	120/240	2501K182G04	153	13	13	2	15
7561ZX2699	25KVA EC&S	120/240	2501K182G05	160	13	13	4	25
7561ZX2999	37.5 KVA EC&S	120/240	2501K185G22	140	8	8	4	37.5
7561ZX3099	50 KVA EC&S	120/240	2501K185G13	120	13	13	4	50
7561ZX3199	10 KVA EC&S	120/240	2501K182G13	120	13	13	2	10
7561ZX3299	10 KVA EC&S	120/240	2501K182G45	110	13	13	2	10
7561ZX3399	15 KVA EC&S	120/240	2501K182G51	140	13	13	2	15
7561ZX3499	37.5 KVA EC&S	120/240	2501K185G24	120	8	8	4	37.5
7561ZX3599	50 KVA EC&S	120/240	2501K185G23	130	13	13	4	50
7561ZX5299	50 KVA EC&S	120/240	2501K185G46	110	13	13	4	50
7561ZX5399	37.5 KVA EC&S	120/240	2501K185G47	130	13	13	4	37.5
7561ZX5599	50 KVA EC&S	120/240	2501K185G51	160	13	13	4	50

REVISION

18) N. Adams 8/08/06 Correct ZX3299 & ADD ZH3999 ECN: F1004	19) N, Adams 09/07/06 Correct ID # 7561ZH2599, ___ 2999	16) N. Adams 10/25/04 Correct 7561ZX1899 ID#	17) N. Adams 4/13/06 Add 7561ZH4099
---	---	---	--

MADE BY: R. GILLAND 9-OCT-01	APPROVAL	ECI	DRAWING NO. 3 2B128001
ISSUED BY: Nicholas Adams 09/07/06			

A1-18A

Sep-06

OUTLINE: BREAKER ON A BRACKET ASSEMBLY

Bracket Mounted T1/T12 Circuit Breaker Installation.

These instructions apply to bracket mounted T1 and T12 circuit breakers with and without emergency overload features.

With Emergency Overload

1. To prepare for installation remove the bracket mounted breaker and it's associated operating handle from it's packaging making sure that the operating handle shipped with the particular breaker stays with it. Adjustment will be lost if this is not adhered to. Remove the mounting nut from the operating handle and remove the cotter pin from the emergency overload arm assembly and slide the assembly off the shaft. The kit is now ready for installation.
2. Insert the breaker/bracket into the transformer tank and align the mounting hole with the hole in the tank wall. Insert the operating handle through the hole in the tank wall and the hole in the bracket The center depression on the circumference of the operating detail must fit over the protrusions in the tank wall and bracket mounting holes. Install the mounting nut and tighten. Torque to 200- 250 inch pounds.
3. Move the emergency lever on the breaker to the normal position. (All the way to the left when looking down into the tank) . Move the emergency overload lever on the operating detail as far as it will go in an clockwise direction.
4. Slide the emergency overload arm assembly onto the shaft taking care that the roll pin on the breaker overload lever is in the slot in the arm. Line up the holes in the bushing on the arm assembly with the hole in the shaft and insert the cotter pin.
5. Install the meter seal.
6. Attach the operating rod which has been pre assembled to the circuit breaker to the bent shaft of the operating detail with the cotter pin. Secure cotter pin.

Mechanical installation is now complete.

Without Emergency Overload.

1. To prepare for installation remove the bracket mounted breaker and its associated operating handle from it's packaging making sure that the operating handle shipped with the particular breaker stays with it. Adjustment will be lost if this is not adhered to. Remove the mounting nut from the operating handle. This kit is now ready for installation.
2. Insert the breaker/bracket into the transformer tank and align the mounting hole with the hole in the tank wall. Insert the operating handle through the hole in the tank wall and the hole in the bracket The center depression on the circumference of the operating detail must fit over the protrusions in the tank wall and bracket mounting holes. Install the mounting nut and tighten. Torque to 200- 250 inch pounds.
3. Attach the operating rod which has been pre assembled to the circuit breaker to the bent shaft of the operating detail with the cotter pin. Secure cotter pin.

Mechanical installation is now complete.